

LS7000 LEVEL SWITCH OWNERS MANUAL

- ◆ INSTALLATION
- ◆ CALIBRATION
- ◆ TROUBLESHOOTING
- ◆ WARRANTY

**BABBITT
INTERNATIONAL, INC.**

**P.O. Box 70094
Houston, TX 77270
(713) 467-4438**

TABLE OF CONTENTS

	Page
<u>1. Description -----</u>	<u>1</u>
<u>A. General Description -----</u>	<u>1</u>
<u>B. Specifications -----</u>	<u>1</u>
<u>2. Theory of Operation -----</u>	<u>2</u>
<u>3. Installation-----</u>	<u>2</u>
A. <u>Inspection and Operation Check -----</u>	<u>2</u>
B. <u>Physical Installation -----</u>	<u>2</u>
C. <u>Removing Electronics-----</u>	<u>3</u>
D. <u>Typical Applications and Wiring Diagrams -----</u>	<u>3</u>
1) <u>LS7000 Terminal Layout -----</u>	<u>3</u>
2) <u>Ladder Diagrams -----</u>	<u>5-6</u>
<u>4. Calibration -----</u>	<u>7</u>
A. <u>Setting the Time Delay -----</u>	<u>7</u>
B. <u>Fail Safe Selection -----</u>	<u>7</u>
C. <u>Sensitivity Calibration -----</u>	<u>7</u>
<u>5. Maintenance and Troubleshooting -----</u>	<u>8</u>
<u>6. Warranty -----</u>	<u>9</u>

LS7000 LEVEL SWITCH

1. DESCRIPTION

A. General Description

The LS7000 is a point level switch that detects the presence or absence of material in a bin, silo, tank or other container. The basic unit is made up of a solid stainless steel probe attached to an explosion proof housing. Inside the explosion proof housing are all calibration adjustments and sensing electronics. The unit is calibrated in the absence of material and an internal relay changes state when material is detected.

B. Specifications

Electrical

Power:	115 VAC (±15%) 50/60 Hz. 2 watts, standard. (12 VDC, 24 VDC or 230 VAC optional)
Output	2 Form C contacts, DPDT relay, 5 amp resistive At 125, 250 VAC; 30 VDC
Fuse:	On board, 250 mA @ 125 volts
Fail Safe:	Selectable high or low level
Time Delay:	Selectable: ON or OFF delay Adjustable: 1/8 sec to 2 hrs.
RF Frequency:	Approximately 1.3 MHz

Environmental

Hazardous Area:	Class I, Group D, Class II, Group E, F, G
Temperature:	Probe: -30° F to 400° F Electronics: -40° F to 185° F
Pressure:	Probe: 1500 psi @ 75° F. Higher ranges available on request.
Construction:	Probe: All wetted parts, 316 SS Teflon and Viton. A Halar coating can be applied to the probe when applicable. Electronics: Housed in cast aluminum explosion proof enclosure.

Specifications subject to change without notice.

C. Ordering Information

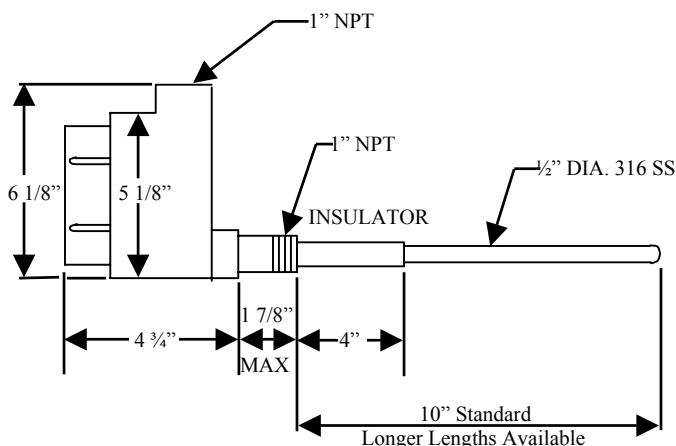
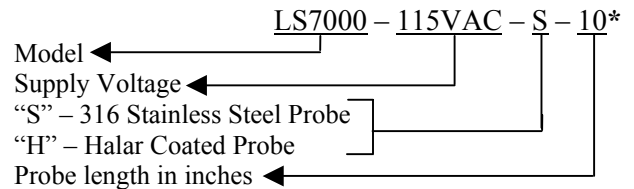

FIGURE 7.1



*This describes an LS7000, powered by a 115 VAC, with a 316 SS probe, 10" long. The probe length is measured from the end of the nipple to the tip of the probe.

2. THEORY OF OPERATION

The LS7000 employs a radio frequency (RF) balanced impedance bridge circuit to detect if the probe is in contact with the material that is to be sensed.

When material is not in contact with the probe, the bridge is balanced by turning the adjustment pot to find the threshold where the red led goes out.

When material is in contact with the probe, the bridge becomes unbalanced and the comparing circuit realizes the change. This causes the relay to change state.

3. INSTALLATION

***CAUTION:** ALL INSTALLATION AND WIRING MUST CONFORM TO NEC AND ALL OTHER LOCAL ELECTRICAL CODES. TAKE SPECIAL CARE IN OBSERVING HAZARDOUS AREA SAFETY PROCEDURES. WE ASSUME NO LIABILITY FOR IMPROPERLY INSTALLED OR WIRED UNITS.

A. Inspection and Operation

After unpacking the LS7000, visually inspect the unit for any damages. Please advise the factory or your local distributor of any damage. Before installing the unit, a simple operational check can be performed.

***THIS IS AN EXCELLENT TIME TO SET THE TIME DELAY IF IT IS TO BE USED IN YOUR APPLICATION.** (See calibration instructions, section 4, A)

On the bench, hook up the appropriate power to L1 and L2. The operating voltage of the LS7000 is marked on the power supply board.

Hold the unit so that the probe is not touching any surface and press the test switch.

When the test switch is depressed, the red led should come on. This simulates product touching the probe. If a timing mode has been selected it will operate as if installed.

NOTE: The timing mode can be adjusted when checking the unit but the sensitivity adjustment **MUST BE MADE AFTER** the unit is installed where it will be used.

B. Physical Installation

- 1) The LS7000 is installed into the vessel wall using a 1" NPT connection. This can be either a threaded coupling or a tapped entry such as a flange.
- 2) The teflon insulator should always extend at least 2" through the vessel wall.
- 3) Always check for physical room around the location you have chosen to allow for installation. Allow 3.25" turning radius to screw the probe in and clearance above for the length of the probe.
- 4) **CAUTION:** Always take the necessary safety precautions when cutting or welding in the coupling for the LS7000.
 - a) Tag and lock out the electrical power to the equipment that services the vessels.
 - b) Check liquid or dry powders that create a gas in the vessel for oxygen as well as the explosion factor. (All dust will explode.)
 - c) Vessels that are cross vented have to be isolated.
- 5) Screw the LS7000 into the connection provided. In dry material application, no sealant on threads is required. On liquid, teflon or a good pipe thread sealant may be used.
- 6) The LS7000 has a 1" NPT conduit entry. When wiring these units, conform to the National Electrical Code and any other city or company codes.
- 7) Always install the electrical connection into the 1" NPT on the LS7000 so water will not follow the connection routing into the threads of the 1" NPT hub. To guarantee that condensation and water will stay outside the unit, install an EYSM unilet before each LS7000 and fill with explosion proof sealing cement.
- 8) When required, the LS7000 probe can be bent to meet your special application. Remember to allow 2" of clearance between the probe and the vessel wall. If the probe is to be used in a pressure application, the factory must bend the probe to your specifications.
- 9) Location of probes on high level installations is more critical on dry material than liquids. Note the following:

- a) For dry materials, mount the LS7000 in the top of the vessel whenever possible. (This allows you to lengthen the probe if necessary.)
- b) Avoid mounting the LS7000 near the product inlet, vent return lines, dust collectors and vessel discharge openings on dry materials. Turbulence around these areas can cause erratic detection unless the probe is long enough. On old installations it might be wise to fill the vessel first to determine the length or location of the probe. CAUTION: Always take safety precautions before opening vessels for such inspection. We recommend a 36" top mounted high level probe in storage silos and a 24" in smaller vessels such as use bins.
- c) On gravity filled vessels, take into consideration the angle of repose formed by the product.
- d) On dry product that flows like water (starch), when using the LS7000 to stop the flow by means of a butterfly valve or knife gate, make sure the probe is long enough to allow time to close these slow moving valves.
- e) In small vessels where a good location is hard to find, it may be necessary to put a baffle plate between the probe and the product inlet to keep product off of the probe as it fills. (A short time delay could also solve this problem.)

C. Removing the Electronics

- 1) To remove the sensing card, simply unplug it from the power supply card. When reinstalling, this card is made so that it cannot be plugged in backwards.
- 2) To remove the power supply card you must:
 - a) Disconnect supply power at main power source.
 - b) Remove sensing card.
 - c) Disconnect wires from terminal strip.
 - d) Remove green grounding screw.
 - e) Unplug blue antenna lead.
 - f) Hold the top of the card guide and lift out.
 To reinstall, reverse the above procedure.

D. Typical Applications and Wiring Diagrams

As follows:

LS7000 TERMINAL LAYOUT

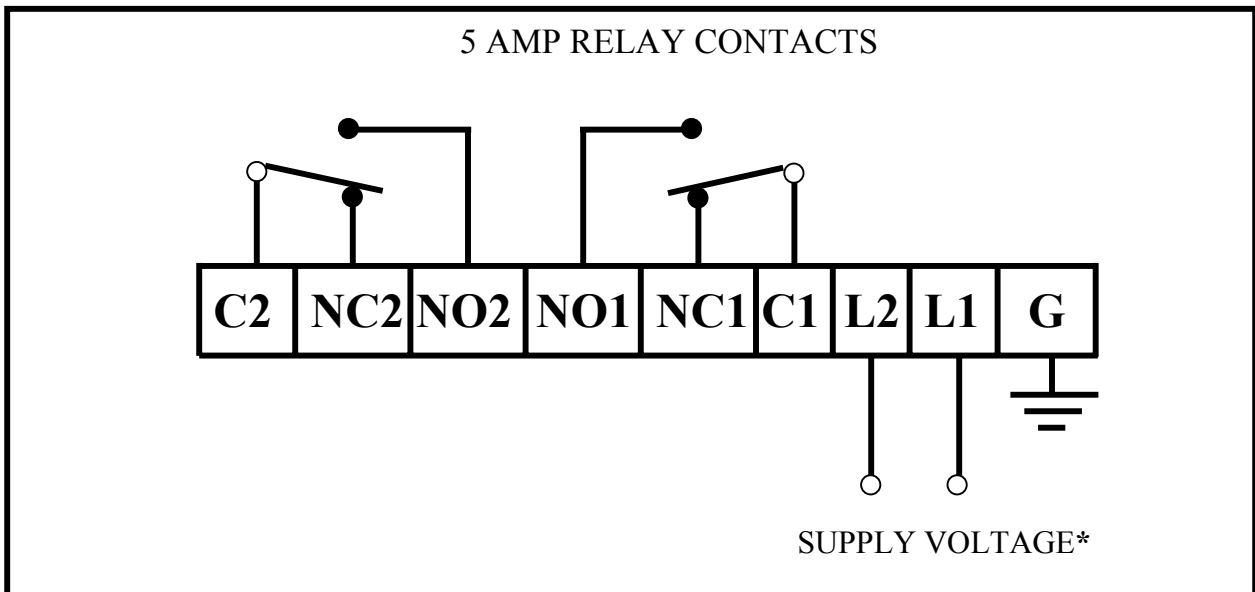

***NOTE:** EACH LS7000 POWER SUPPLY IS INTENDED FOR ONLY ONE SUPPLY VOLTAGE. THIS VOLTAGE IS PRINTED ON THE POWER SUPPLY BOARD. FOR 115 VAC OR 230 VAC UNITS, HOOK UP THE HOT LEAD TO L1 AND THE NEUTRAL TO L2, WITH APPROPRIATE GROUND. FOR 12 VDC OR 24 VDC UNITS, HOOK THE POSITIVE VOLTAGE TO L1 AND THE COMMON OR GROUND TO L2.

FIGURE 7.2

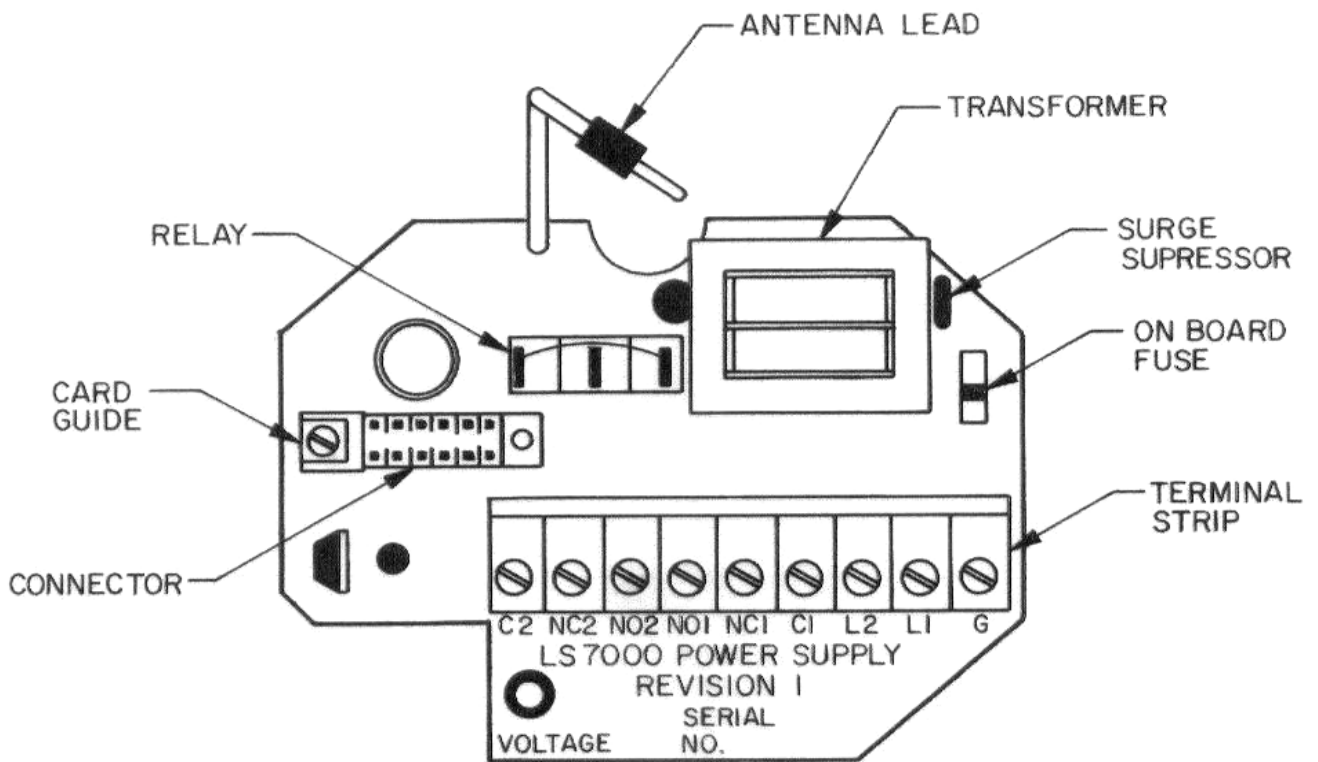

POWER SUPPLY BOARD

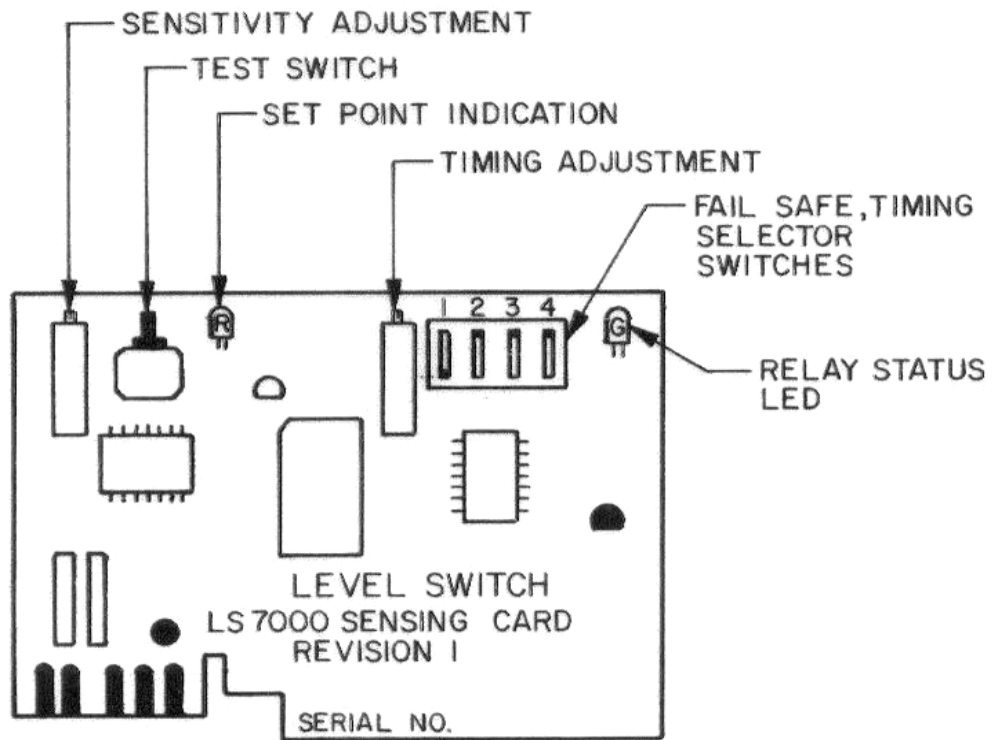

SENSING CARD

FIGURE 7.3

TYPICAL WIRING

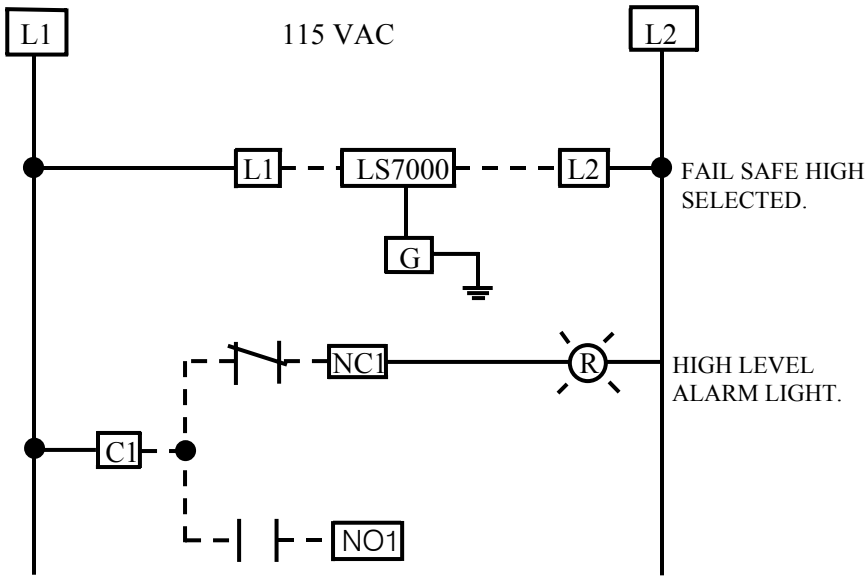

APPLICATION
HIGH LEVEL ALARM

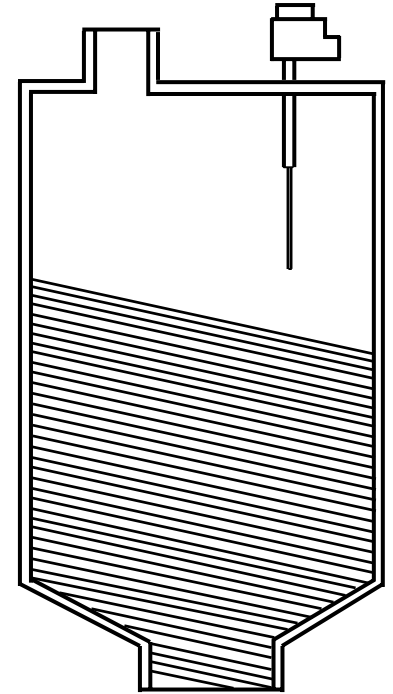
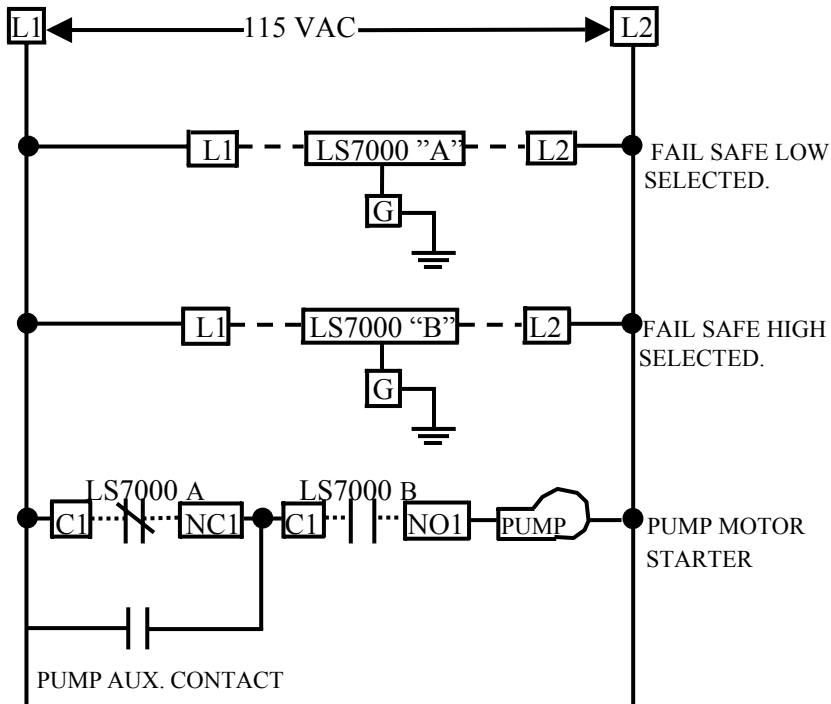

FIGURE 7.4

TYPICAL WIRING



APPLICATION

AUTOMATIC FILLING OF TANK.
(WHEN LEVEL FALLS TO POINT "A",
A PUMP COMES ON TO FILL TO
POINT "B", THEN TURNS OFF.)

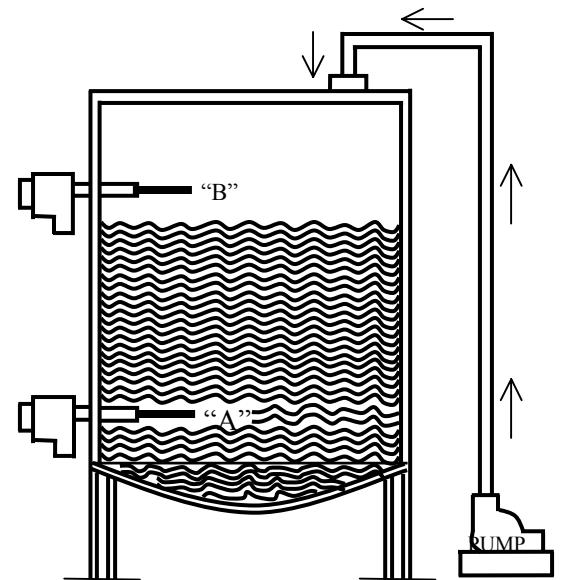
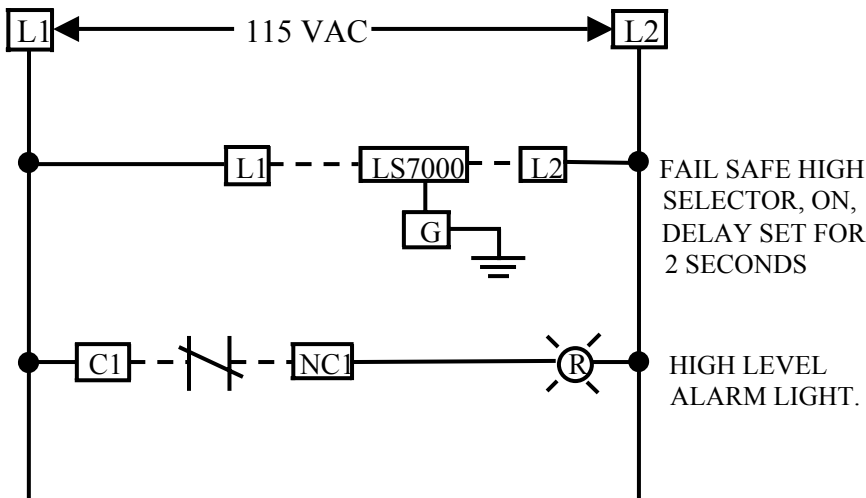

FIGURE 7.5

TYPICAL WIRING



WHEN THE FLUID REACHES POINT "A", IT MUST REMAIN THERE FOR 2 SECONDS BEFORE THE INDICATOR LAMP WILL COME ON.

NOTE: PLEASE REVIEW FAIL SAFE SELECTION INSTRUCTIONS, SECTION IV B.

APPLICATION

HIGH LEVEL ALARM USING THE TIME DELAY TO IGNORE SPLASHING OR WAVE ACTION. (TIME ON, INSTANT OFF)

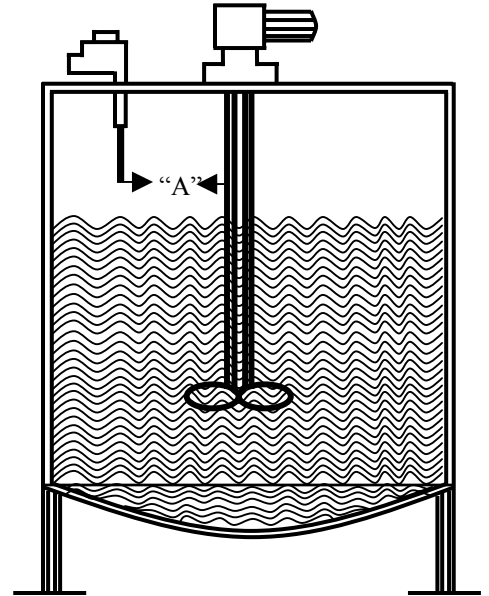
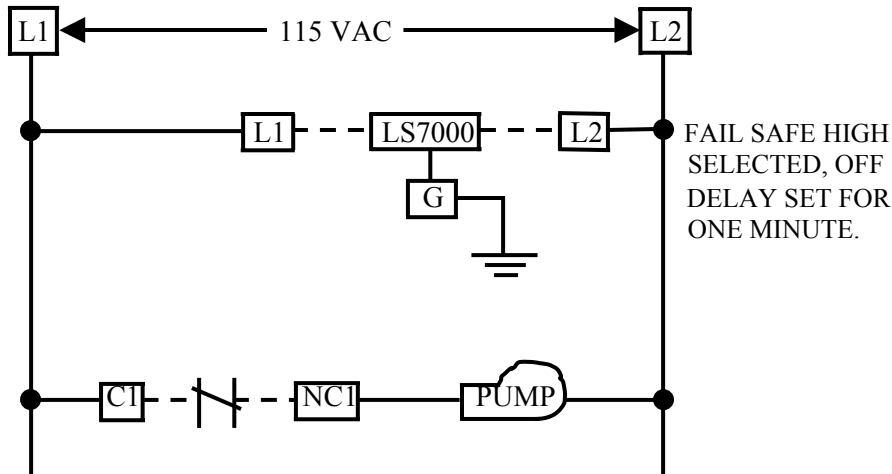

FIGURE 7.6

TYPICAL WIRING



WHEN THE WATER LEVEL REACHES POINT "A", THE PUMP WILL TURN ON AND CONTINUE TO RUN FOR 1 MINUTE AFTER THE WATER FALLS BELOW THE PROBE.

NOTE: PLEASE REVIEW FAIL SAFE SELECTION INSTRUCTIONS, SECTION IV B.

APPLICATION

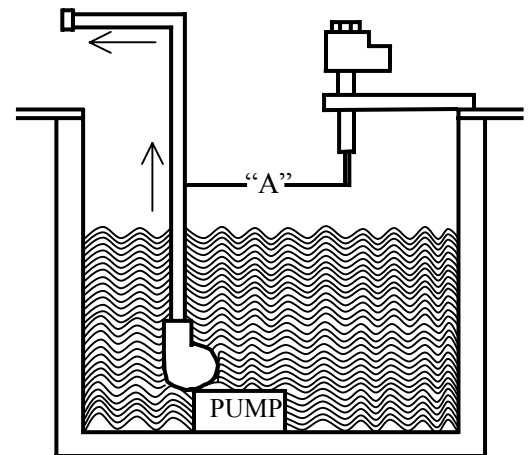

FIGURE 7.7

4. CALIBRATION

PLEASE READ THE ENTIRE CALIBRATION PROCEDURE BEFORE CALIBRATING THE LS7000.

If no time delay is required, turn the time adjustment pot completely CCW and set S1 down, S2 up. The potentiometer has 18 turns and freewheels at the end of its travel without damage. You may hear “clicks” at the end of travel.

A. Setting the Time Delay

- 1) Setting the timing mode, either on delay or off delay is done by positioning S3 and S4 as shown in the chart below.

NOTE: S3 and S4 also select fail safe high level (FSH) or fail safe low level (FSL).

- 2) Select the timing range using S1 and S2 as shown on the chart below.
- 3) Adjust the time adjustment potentiometer clockwise to increase time or CW to decrease until the exact time delay is arrived at. The test switch may be depressed to start the timing when checking timing sequence.

NOTE: For long timing ranges you can set the timer for a shorter range, then change the range Switches (S1 and S2) to increase the time. For example, the desired time delay is 15 minutes. This is equal to 900 seconds. By setting S1 down and S2 up and adjusting the timer to approximately 28 seconds, the ratio on this range is 1. To increase this range by 32, move S1 up and S2 up. 32x28 seconds equals approximately 15 minutes.

B. Fail Safe Selection

The fail safe feature provides a “false alarm” in case of power outage or major component failures. When properly selected, the fail safe feature can protect equipment or alert you of a unit failure.

Fail Safe High (FSH) means that the relay is energized when NO PRODUCT is touching the probe. The green led indicates relay status and is on when the relay is energized. When product comes into contact with the probe, the relay is de-energized.

Fail Safe Low (FSL) means that the relay is energized when PRODUCT IS touching the probe.

NOTE: Due to the wide variety of applications and possible control or alarm functions, the proper fail safe selection will depend on your circumstances. Please call your distributor or the factory if you need assistance.

TIMING RANGE

S1	S2	TIME	RATIO
DN	UP	1/8 sec - 35 sec	1
UP	DN	1/2 sec - 140 sec	4
UP	UP	4 sec - 18 min	32
DN	DN	32 sec - 2 hrs	260

FAILSAFE TIMER MODE

S3	S4		
UP	UP	ON	FSL
DN	UP	DELAY	FSH
DN	DN	OFF	FSL
UP	DN	DELAY	FSH

C. Sensitivity Calibration

The LS7000 should be calibrated when no material is touching the probe and when the unit is installed where it will be used.

- 1) Observe the red LED. If it is on, go to step 3.
- 2) If the red LED is off, turn the sensitivity adjustment potentiometer CW until it comes on.
- 3) Turn the sensitivity adjustment pot CCW until the red LED just goes out and continue to turn the pot CCW at least ½ of a turn. This sets the unit to its maximum stable sensitivity. If in your application this is too sensitive, you can turn the sensitivity adjustment pot further CCW. Always bring the product into contact with the probe after calibration to assure proper performance.

NOTE: The green LED indicates relay status. The relay is energized when the green LED is on.

Every LS7000 has a diagram inside the screw cover to serve as a reminder to those who have calibrated the unit before. This shows the calibration adjustments and indicators. This diagram is reproduced below.

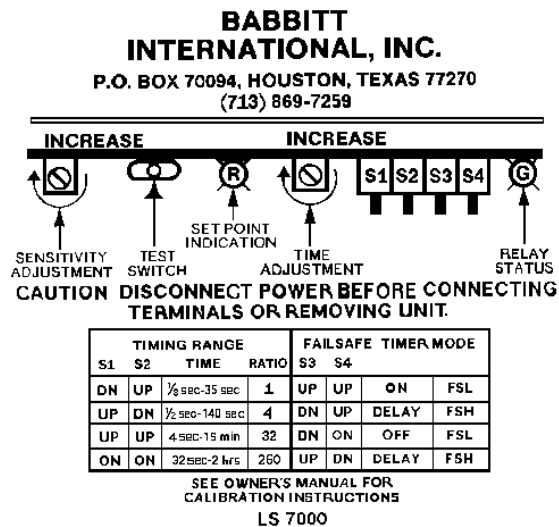

SPECIAL CALIBRATION NOTES:

For some products, the LS7000 can be calibrated with product touching the probe. To do this, turn the sensitivity adjust pot CW until the red LED just comes on and continue CW for 1/8 to ¼ of a turn. Always check to see if the unit resets in the absence of product.

5. MAINTENANCE AND TROUBLESHOOTING

No routine maintenance is required other than keeping the interior of the unit clean and free of dirt, dust and other contaminants.

The LS7000 consists of three main sub-assemblies. These are the enclosure with the antenna probe, the power supply board and the sensing card. The following troubleshooting guide will assist in determining how to correct most of the problems which may occur in the field. Review the Installation and Calibration procedures in sections 3 and 4.

PROBLEM	POSSIBLE CAUSE	SOLUTION
RED LED cannot be adjusted to turn on.	Antenna lead not connected. No power to unit. Blown on-board fuse. Bad sensing card.	Plug antenna lead into probe. Check for correct power to unit. Replace fuse. Repair or replace card.
RED LED remains on at all times	Antenna probe is shorted to case or ground. Bad sensing card.	Unplug banana plug and position it so that the bare end is not touching anything. Turn calibration pot 20 turns CCW. LED should go out. If it does, repair, replace or clean antenna probe. If LED does not go out, replace electronics. Repair or replace card.
Unit triggers when material touches probe, but will not reset when material recedes from probe or unit and gives false alarm.	Improper amount of probe. Improper calibration procedure. Excessive material build-up on probe. Probe is mounted in flow of material.	Contact factory or dist. See section 4C. Perform "dirty probe calibration": Recalibrate with built up material on probe. See section 4C. Revise mounting or use time delay. See sec. 4A

Unit will not detect material.	Improper calibration. Antenna lead not plugged into probe. Unit was calibrated with material touching probe.	See calibration instructions, section 4. Plug antenna lead into probe. Be sure material is not touching probe and recalibrate.
Unit will not stay in calibration.	Poor grounding of unit to vessel.	Provide secure ground connection.
Relay operates properly, but no signal at terminals.	Burned or broken lands on the printed circuit board. Bad relay contacts.	Turn off power. Remove module from housing and inspect lands on printed circuit for damage. Replace if necessary. Replace relay or return for repair.

PLEASE CONTACT THE FACTORY OR YOUR DISTRIBUTOR IF YOU HAVE ANY QUESTIONS OR NEED ASSISTANCE.

6. WARRANTY

All components of the LS7000 are warranted to be free from defects in material and workmanship for a period of two years from the date of purchase. This warranty applies to general purchaser and to components installed, serviced and operated according to instructions.

Babbitt International, Inc. will repair or replace, at its option, FOB at its plant or any other location designated, any part which proves to be defective in manufacture or workmanship.

All claims must be made in writing within the warranty period. No claims outside of the warranty period will be honored.

Warranties are not applied to any components which have been damaged by improper installation, use, exposure to unusual atmospheric conditions or components which have been misused, abused, damaged by neglect or accident. This warranty shall not apply to any components which have been altered or repaired without the prior written consent of Babbitt International, Inc.

Babbitt International, Inc. assumes no responsibility or liability for any labor or material back charges, without written authorization. Any products returned must be with prior written authorization.

THE FOREGOING IS IN LIEU OF ALL OTHER WARRANTIES, EXPRESSED OR IMPLIED, INCLUDING ANY WARRANTIES OF MERCHANTABILITY AND/OR FOR FITNESS FOR PARTICULAR PURPOSE, AND BABBITT INTERNATIONAL, INC. ASSUMES NO OTHER LIABILITIES EXPRESSED OR IMPLIED. BABBITT INTERNATIONAL, INC. SHALL NOT BE LIABLE FOR NORMAL WEAR AND TEAR, NOR FOR DIRECT, INCIDENTAL OR CONSEQUENTIAL DAMAGES. IN NO EVENT SHALL BABBITT INTERNATIONAL INCORPORATED'S LIABILITY EXCEED THE PRICE OF ITS PRODUCT AT THE TIME OF PURCHASE.